

# EVO-RP1

---

::: Receipt Printer User's Manual :::

**All specifications are subject to change without notice**

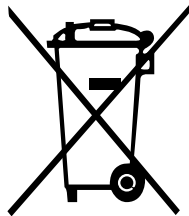

***Disposal of Old Electrical & Electronic Equipment (Applicable in the European Union and other European countries with separate collection systems)***

This symbol on the product or on its packaging indicates that this product shall not be treated as household waste. Instead it shall be handed over to the applicable collection point for the recycling of electrical and electronic equipment.

For more detailed information about recycling of this product, please contact your local city office, your household waste disposal service or the shop where you purchased the product.



## TABLE OF CONTENTS

<b>1. Parts Identifications</b>	3
<b>2. Setting up the printer</b>	4
2.1 Unpacking	4
2.2 Connecting the cables	5
2.3 Loading the paper	8
2.4 Dip switch setting	10
<b>3. Control panel and other functions</b>	14
3.1 Control panel	14
3.2 Error Indicator	14
<b>4. Self Test</b>	15
<b>5. Hexadecimal Dump</b>	15
<b>6. Specifications</b>	16
6.1. General Specifications	18
6.2. Auto Cutter Specifications	18
6.3. Interface	18
6.4. Electrical Characteristics	18
6.5. Environmental Requirements	19
6.6. Reliability	19
6.7. Certification	19
<b>7. Command List</b>	20

## 1. Parts Identifications

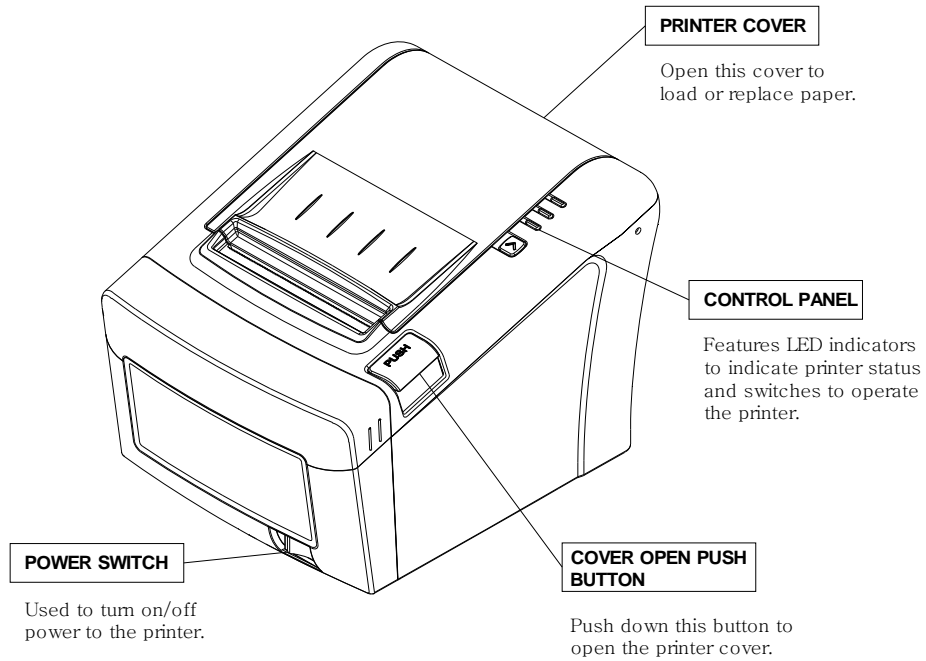

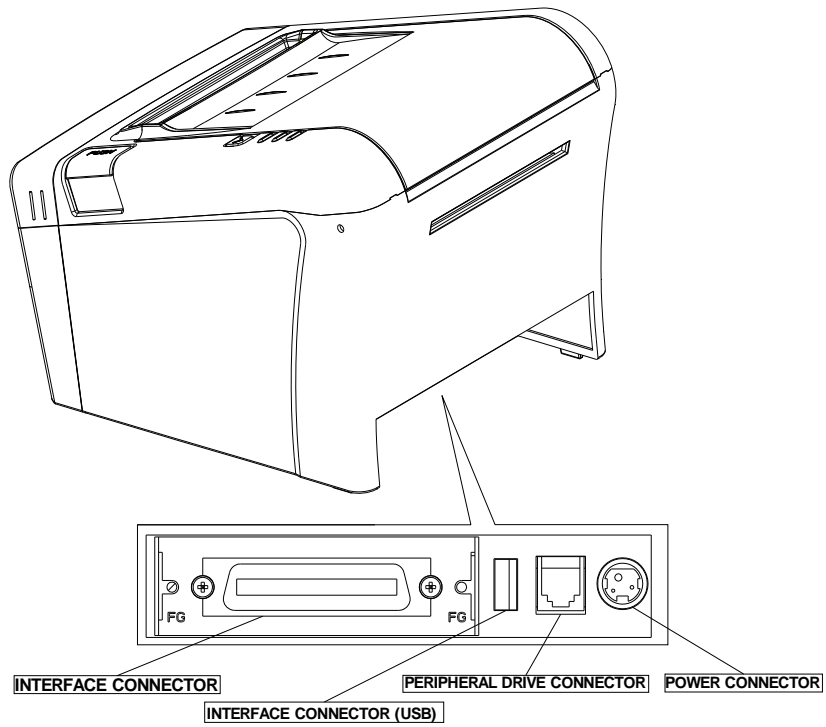

## 2. Setting Up the Printer

### 2-1. Unpacking

Your printer box should include these items. If any items are damaged or missing, please contact your dealer for assistance.

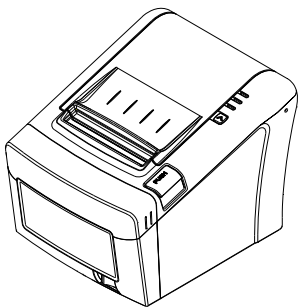

The Printer

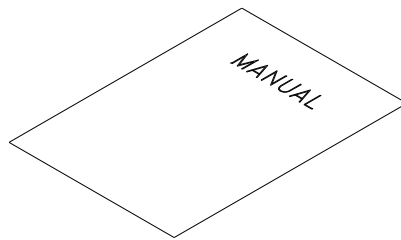

User's Manual

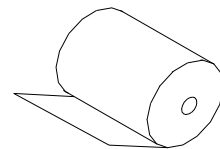

Roll Paper

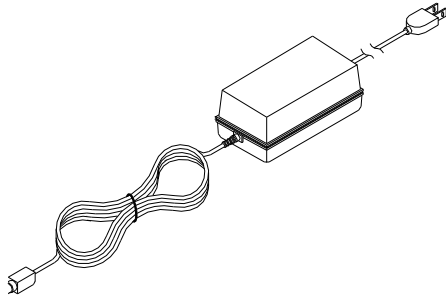

Power Adaptor

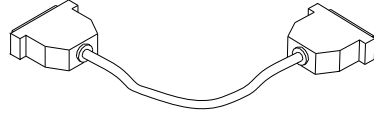

Interface Cable

## 2-2. Connecting the Cables

All cables connect to the connector panel on the back of the printer which is shown below:

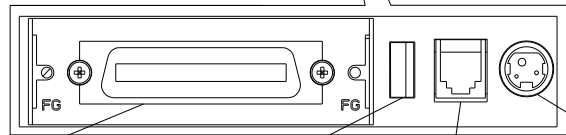
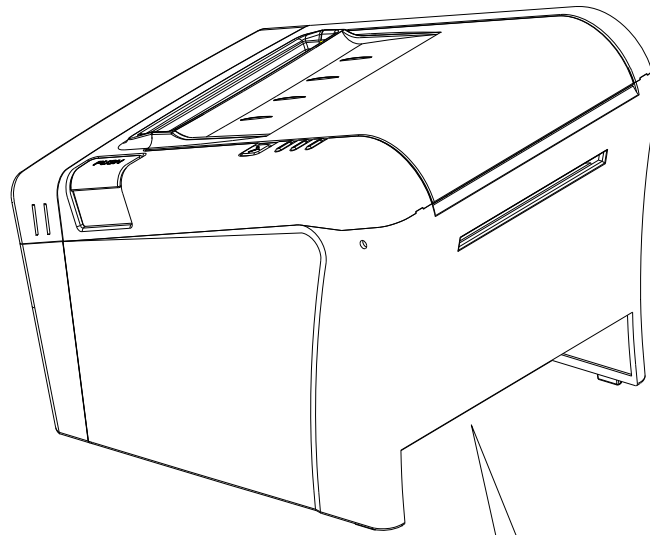

**INTERFACE CONNECTOR**

For connection to a host computer.

**INTERFACE CONNECTOR (USB)**

For connection to a host computer.

**PERIPHERAL DRIVE CONNECTOR**

Connects to peripheral units such as cash drawer, etc.  
Do not connect this to a telephone.

**POWER CONNECTOR**

For connection of the AC adapter.  
Never unplug the AC adapter while the printer is on.

Before connecting any of the cables, make sure that both the printer and the computer are turned off.

## 2-2-1. Interface Connector

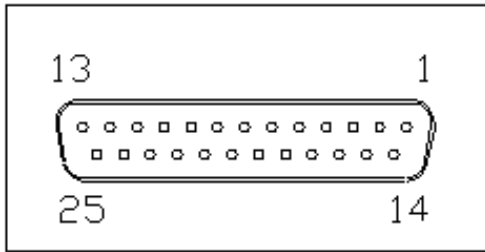

<D-SUB 25 Female Serial>

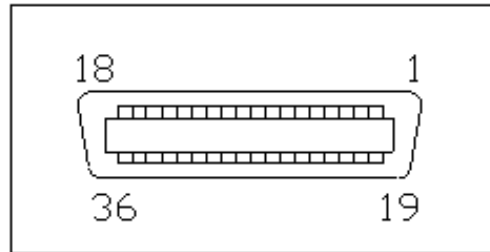

<Centronics Parallel>

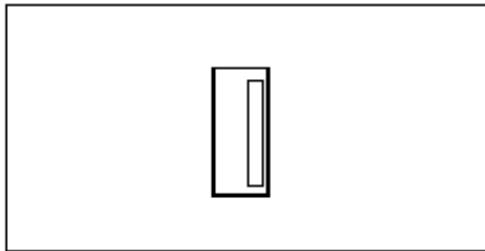

<USB "A" Type>

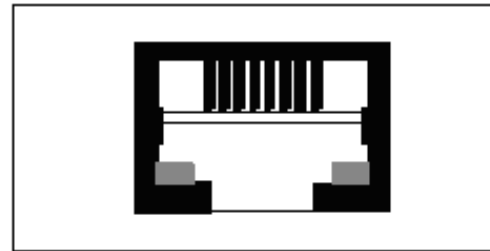

<Ethernet>

**- USB Interface**

PIN	SIGNAL	I/O	DESCRIPTION
1	+5V	-	+5V
2	DATA-	-	Printer transmit data line
3	DATA+	-	Printer transmit data line
4	GND	-	System Ground

**- Serial Interface**

PIN	SIGNAL	I/O	DESCRIPTION
2	TxD	Output	Printer transmit data line RS-232C level
3	RxD	Input	Printer receive data line RS-232C level
4, 20	DTR	Output	Printer handshake to host line RS-232C level
6	DSR	Input	Data Send Ready
1, 7	GND	-	System Ground

**- Centronics Parallel Interface**

PIN	SIGNAL	I/O	DESCRIPTION
1	STROBE-	Input	Synchronize signal Data received
2~9	DATA0~7	Input/Output	Data bit Transmitted 0~7

10	ACK-	Output	Data receiving completed.
11	BUSY	Output	Impossible to print of data receiving.
12	PE	Output	Paper empty
13	SELECT	Output	Printer status for ON/OFF line
14	AUTO FEED-	Input	Paper auto feed signal
15	GROUND	-	System ground
16	GROUND	-	System ground
17	NC	-	
18	LOGIC-H	-	+5V
19~30	GROUND	-	System ground
31	INIT-	Input	Initialize
32	ERROR-	Output	Printer error
33	GROUND	-	System ground
34	NC	-	
35	+5V	-	+5V
36	SELLECT IN-	Input	Printer select signal

### - Ethernet Interface

PIN	SIGNAL	I/O
1	Data Out +	Output Data +
2	Data Out -	Output Data -
3	GND	Ground
4	Data IN +	Input Data +
5	Data IN -	Input Data -
6	N.C	
7	N.C	
8	N.C	

### 2-2-2. Cash Drawer Connector

The printer can operate two cash drawers with a 6 pin RJ-11 modular connector. The driver is capable of supplying a maximum current of 1.0A for 510ms or less when not printing.

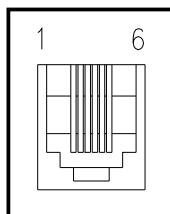

PIN	SIGNAL	DESCRIPTION
1	Signal GND	-
2	Drawer kick-out drive signal 1	Output
3	Drawer open/close signal	Input
4	+24V	-
5	Drawer kick-out drive signal 2	Output
6	Signal GND	-

## 2-3. Loading the Paper Roll

Notes: Be sure to use paper rolls that meet the specifications. Do not use paper rolls that have the paper glued to the core because the printer cannot detect the paper end correctly.

1. Turn off power switch.
2. Make sure that the printer is not receiving data; Otherwise, data may be lost.
3. Open the paper roll cover by pushing down the cover-open push button.

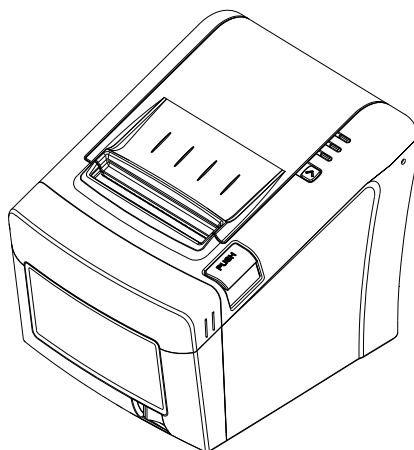

3. Remove the used paper roll core if there is one inside.
4. Insert new paper roll as shown.

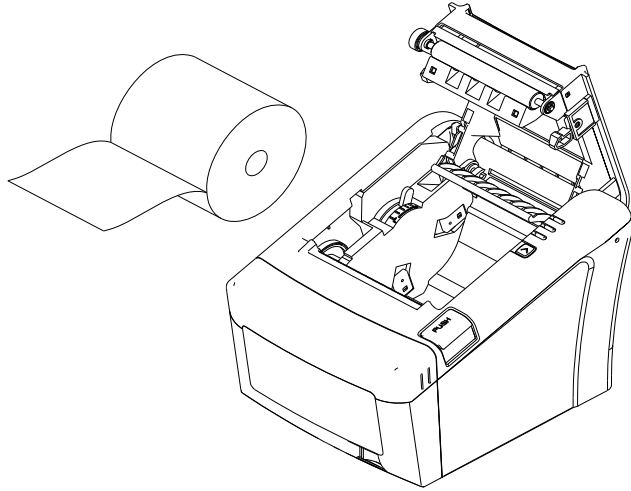

5. Note the correct direction that the paper comes off the roll:

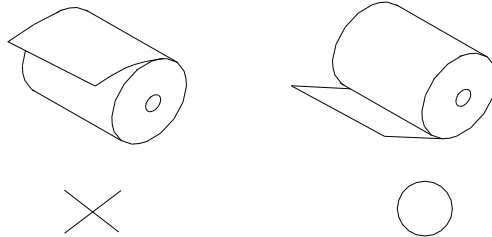

6. Pull out a small amount of paper as shown. Then, close the cover.

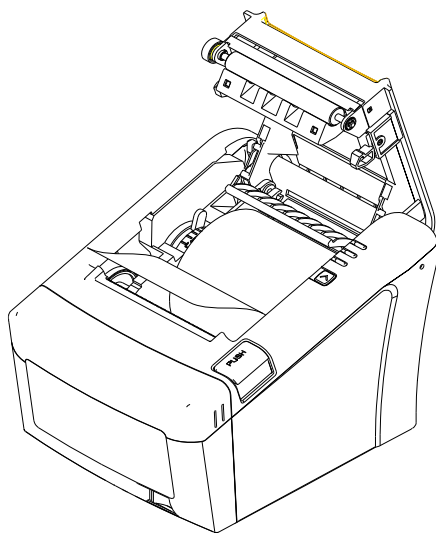

7. Tear off the paper as shown.

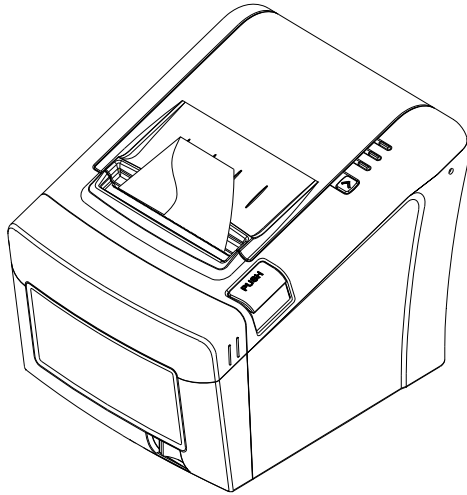

## 2-4. DIP SWITCH SETTING

The printer is set up at the factory to be appropriate for almost all users. It does, however, offer some settings for users with special requirements.

It has DIP switches that allow you to change communication settings, such as handshaking and parity check, as well as print density.

Your printer has two sets of DIP switches. The functions of the switches are shown in the following tables.

**※ Note :** Turn power off unplug the printer. Open the Dip Switch cover to change settings.

### 2-4-1. Serial Interface Specification

#### DIP Switch Setting (Standard)

SW	FUNCTION	ON	OFF
2	Hexadecimal	HEXDUMP	NORMAL
5	Cut Mode	Full Cut	Partial Cut
8	Paper Low Mode	Paper Low Detect	Do not detect

#### Baud rate selection

FUNCTION	SW-3	SW-4
Low Power	ON	ON
Normal	OFF	ON
Normal	ON	OFF
Dark	OFF	OFF

#### Parallel Interface

SW	FUNCTION	ON	OFF
6	Bi-direction Mode	Disabled	Enabled

## Serial Interface

SW	FUNCTION	ON	OFF
6	Handshaking	XON/XOFF	DTR/DSR

## Baud rate selection

FUNCTION	SW-9	SW-10
115200 BPS	ON	ON
9600 BPS	OFF	ON
19200 BPS	ON	OFF
38400BPS	OFF	OFF

## CAUTION:

Turn off the printer while removing the DIP switch cover to prevent an electric short, which can damage the printer.

1. Make sure the printer is turned off and unplugged.
2. Remove the DIP switch cover by taking off as shown in the illustration below.

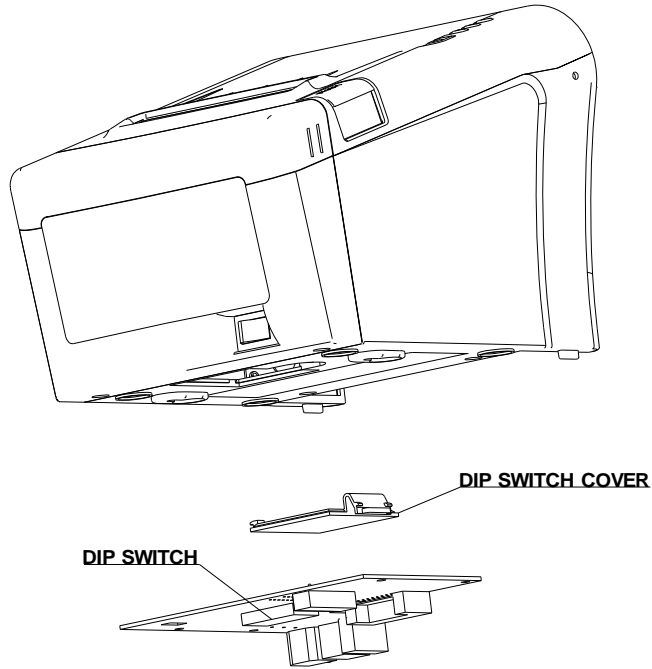

3. Set the switches using a pointed tool, such as tweezers or a small screwdriver.
4. Replace the DIP switch cover.

The new settings take effect when you turn on the printer.

 **CAUTION:**

When the paper cutter is jammed, the top cover might be stuck closed. In this case, repeat power on and off several times.

If the top cover is still stuck, please follow the steps to release the paper jam.

1. Make sure the printer is turned off.
2. Remove cutter cover as shown.

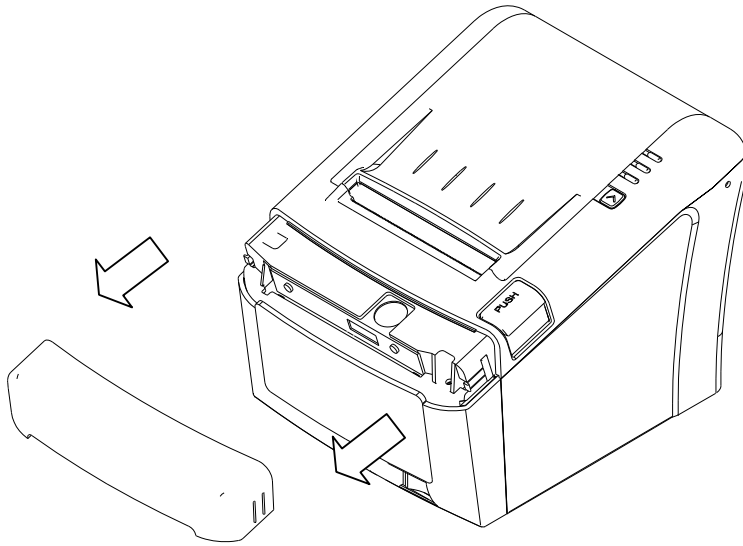

3. Turn screw with a screwdriver until paper is released from the cutter.

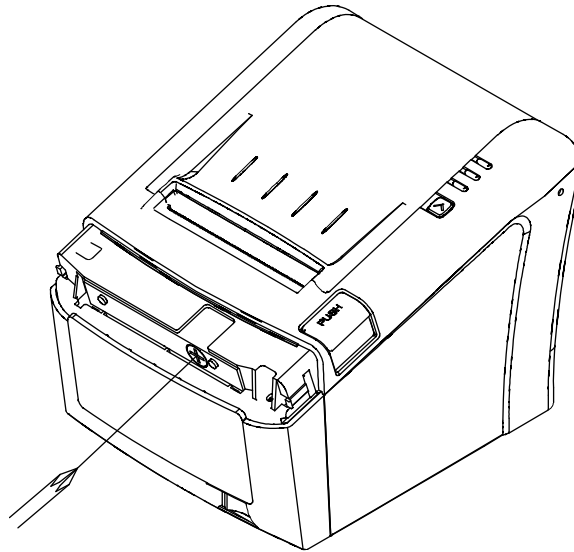

### 3. Control panel and other functions.

#### 3-1. Control panel

You can control the basic paper feeding operations of the printer with the button on the control panel. The indicator lights let you to monitor the printer's status.

#### Control Panel

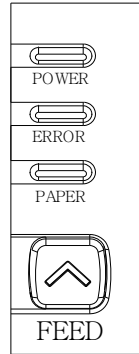

#### Button

The button can be disabled by the ESC c 5 command.

Press the FEED button once to advance paper one line. You can also hold down the FEED button to feed paper continuously.

#### 3-2. Error Indicator

This section explains the different patterns signaled by the two LED indicators located on the top cover of the printer.

STATUS	PAPER	ERROR	POWER	REMARKS
	RED	RED	GREEN	
Power off	OFF	OFF	OFF	Normal power is not supplied to the printer
Power on	OFF	OFF	ON	Normal power is supplied to the printer
On line	OFF	OFF	ON	Normal error-free mode
Cover open	OFF	ON	ON	Close cover
Paper empty	OFF	ON	ON	Insert new paper roll
Paper near end	ON	OFF	ON	Paper is low
Test mode	OFF	OFF	ON	Ignored error led

## 4. Self Test

The self-test lets you know if your printer is operating properly. It checks the control circuits, printer mechanisms, print quality, ROM version and DIP switch settings.

This test is independent of any other equipment or software.

### Running the self test

1. Make sure the printer is turned off and the printer cover is closed properly.
2. While holding down the FEED button, turn on the printer using the switch on the front of the printer to begin the self-test. The Self Test prints the printer settings, cuts the paper, then pauses: (Error LED On)

Self test Printing

Please press the PAPER FEED button.

3. Press the FEED button to continue printing. The printer prints a pattern using the built-in character set.
4. The self test automatically ends and cuts the paper after printing the following:

**\*\*\* Completed \*\*\***

The printer is ready to receive data as soon as it completes the self-test.

## 5. Hexadecimal Dump

This feature allows experienced users to see exactly what data is coming to the printer. This can be useful in finding software problems.

When you turn on the hex dump function, the printer prints all commands and other data in hexadecimal format along with a guide section to help you find specific commands.

To use the hex dump feature, follow these steps:

1. After you make sure that the printer is off and Dip s/w 1-2 are set to ON, turn on the printer.
2. Run any software program that sends data to the printer. The printer prints "Hexadecimal Dump" and then all the codes it receives in a two-column format. The first column contains the hexadecimal codes and the second column gives the ASCII characters that correspond to the codes.

Hexadecimal Dump

1B 21 00 1B 26 02 40 40 .!.& . @ @

1B 25 01 1B 63 34 00 1B .%.. c4 ..

41 42 43 44 45 46 47 48 ABCDEFGH

A period (.) is printed for each code that has no ASCII equivalent.

3. Turn off the printer, and make sure that Dip sw 1-2 are set to off.
4. Turn on the printer.

## 6. Specifications

### Important!

When connecting or disconnecting the power supply from the printer, be sure that the following cautions are observed.

Use a power supply (Limited Power Supply) of DC 24V  $\pm$  10% and more than 2.5A.

Be careful about installing the printer in an area where there is electrical noise.

Take the appropriate measure to protect against electrostatic AC line noise, etc.

### 6-1. General Specifications

(1) Printing Method      Direct line thermal printing.

(2) Print speed            160mm/sec.

(3) Dot density

180 DPI (Hor / Ver)	180 / 180 (0.142mm / 0.142mm dot)
---------------------	-----------------------------------

(4) Printing Width

180 DPI	Max 72mm (512 dots)
---------	---------------------

(5) Dot Pitch            0.141mm X 0.141mm

(6) Number of print columns.  
No. of columns

	Font "A"	Font "B"
180 DPI	42	56

(7) Paper Roll            Refer to chapter 2 for details on loading the Paper.  
Paper width: 82.5mm  
Roll diameter: Max.  $\varnothing$ 83.0mm

(8) Weight                1.7Kg

(9) Overall dimensions

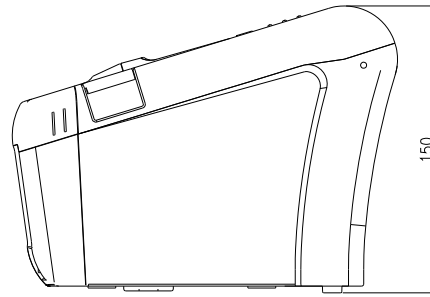
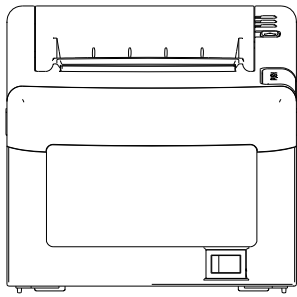
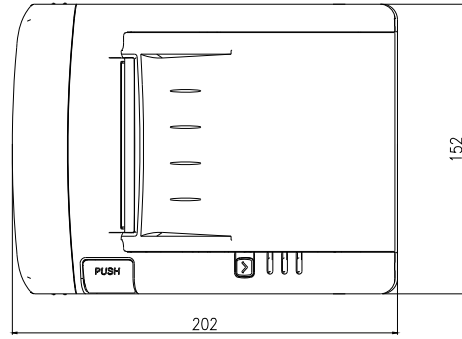

## 6-2. Auto Cutter Specifications

- |                        |   |
|------------------------|---|
| (1) Cutting Frequency  | Max. 30 cuts per minute   |
| (2) Thickness of paper | 0.065 ~ 0.1mm   |
| (3) Cutter Life        | 1.5 million cuts<br>(if the paper thickness is between 65 and 80 $\mu$ m) |

## 6-3. Interface

RS232 Serial Interface, Centronics Parallel Interface(IEEE1284), USB Interface, Ethernet Interface(10Mbps)

## 6-4. Electrical Characteristics

- |                         |   |
|-------------------------|---|
| (1) Input Voltage       | DC 24V $\pm$ 10%  |
| (2) Current Consumption | Operating: Approx. 1.5 A (at ASC□ printing)<br>Peak : Approx. 10 A<br>(at print duty 100%, For 10 seconds or less)<br>Stand-by : Approx. 0.15 A |
| (3) Power Connector     |   |

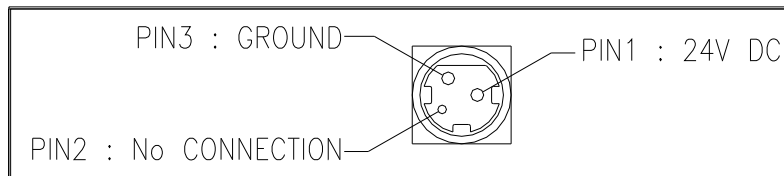

## **6-5. Environmental Requirements**

(1)Operating

Temperature 5° C to 40° C

Humidity 10% to 90% RH (without condensation)

(2)Transport/Storage (except paper)

Temperature -20° C to 60° C

Humidity 10% to 90% RH (without condensation)

## **6-6. Reliability**

(1)MCBF 50 million lines (based on an average printing rate of 12.5% with paper thickness in the range 65µm to 75µm)  
35 million lines (based on an average printing rate of 12.5% with paper thickness in the range 76µm to 150µm)

(2)Head Life 100 million pulses, 150Km

(3)Cutter Life 1.5 million cuts (if the paper thickness is between 65 and 80µm)

## **6-7. Certification**

(1)FCC PART15 CLASS A

(2)CE EMCD/LVD

(3)UL/cUL

(4)MIC

## 7. Command List

No.	Command	Function	REMARKS
1	HT	Horizontal tab	
2	LF	Print and line feed	
3	CR	Print and carriage return	
4	FF	Print and return to standard mode(in page mode)	
5	CAN	Cancel print data in page mode	
6	DLE EOT	Real-time status transmission	
7	DLE ENQ	Real-time request to printer	
8	DLE DC4	Generate pulse at real-time	
9	ESC FF	Print data in page mode	
10	ESC SP	Set right-side character spacing	
11	ESC !	Select print mode(s)	
12	ESC \$	Set absolute print position	
13	ESC %	Select/cancel user-defined character set	
14	ESC &	Define user-defined characters	
15	ESC *	Set bit-image mode	
16	ESC -	Turn underline mode on/off	
17	ESC 2	Select default line spacing	
18	ESC 3	Set line spacing	
19	ESC =	Select peripheral device	
20	ESC ?	Cancel user-defined characters	
21	ESC @	Initialize printer	
22	ESC D	Set horizontal tab positions	
23	ESC E	Turn emphasized mode on/off	
24	ESC G	Turn double-strike mode on/off	
25	ESC J	Print and feed paper using minimum units	
26	ESC L	Select page mode	
27	ESC M	Select character font	
28	ESC R	Select an international character set	
29	ESC S	Select standard mode	
30	ESC T	Select print direction in page mode	
31	ESC V	Turn 90° clockwise rotation mode on/off	
32	ESC W	Set printing area in page mode	
33	ESC \	Set relative print position	
34	ESC a	Select justification	
35	ESC c 3	Select paper sensor(s) to output paper-end signals	
36	ESC c 4	Select paper sensor(s) to stop printing	
37	ESC c 5	Enable/disable panel buttons	
38	ESC d	Print and feed paper <i>n</i> lines	
39	ESC p	General pulse	
40	ESC t	Select character code table	
41	ESC {	Turn upside-down printing mode on/off	
42	FS p	Print NV bit image	
43	FS q	Define NV bit image	
44	GS !	Select character size	

No.	Command	Function	REMARKS
45	GS \$	Set absolute vertical print position in page mode	
46	GS *	Define downloaded bit image	
47	GS /	Print downloaded bit image	
48	GS B	Turn white/black reverse printing mode on/off	
49	GS H	Select printing position of HRI characters	
50	GS I	Transmit printer ID	
51	GS L	Set left margin	
52	GS P	Set horizontal and vertical motion units	
53	GS V	Select cut mode and cut paper	
54	GS W	Set printing area width	
55	GS \	Set relative vertical print position in page mode	
56	GS a	Enable/disable Automatic Status Back(ASB)	
57	GS f	Select font for HRI characters	
58	GS h	Set bar code height	
59	GS k	Print bar code	
60	GS r	Transmit status	
61	GS v 0	Print raster bit image	
62	GS w	Set bar code width	
	< Add >		
1	ESC i	Full cut	
2	ESC m	Partial cut	
3	FS !	Set print mode(s) for Kanji characters	
4	FS &	Select Kanji character mode	
5	FS -	Turn underline mode on/off for Kanji character	
6	FS .	Cancel Kanji character mode	
7	FS 2 c1 d1...dk	Define user-defined Kanji characters	
8	FS C	Select Kanji character code system	
9	FS S 1 2	Set Kanji character spacing	
10	FS W	Turn quadruple-size mode on/off for Kanji character	

**:: MEMO ::**

---



---



---

