

POS X

POINT OF SALE
PERFECTED

barcode scanner

XI3200BT

Wireless Bluetooth LED Barcode Scanner

Wireless Scanning has never been more affordable. Featuring lighting fast scanning speed, extra long battery life, and a light weight ergonomic feel, the XI3200BT the perfect choice for any scanning application desiring the freedom of wireless.

Class 1 Bluetooth Technology

Featuring true Class 1 Bluetooth connectivity (up to 328'), the XI3200BT provides plenty of range for retail and light industrial applications. Coming standard with a convenient recharging base station, the XI3200BT easily connects to any PC, or can be paired with standard Bluetooth device such as a cell phone, PDA or Mobile Computer.



High Performance Optical Engine

The XI3200BT features an aggressive optical scan engine engineered with a lighting fast scan rate and an increased depth of field. The result is near-laser performance with the added durability of no moving parts.

Key Features

- 3 Year Advanced Replacement Warranty
- Reading Distance .65" ~ 14.7"
- 328' Class 1 Bluetooth Range
- Battery Lasts for over 50,000 Scans
- Ergonomic and Light Weight
- No Moving Parts for Increased Durability

XI3200BT Specifications

PART NUMBER	XI3200BT	
PERFORMANCE		
Engine	Linear Imaging	
Light Source	Red LED (660nm) 60mm Array Width	
Optical Sensor	2048 pixels	
Depth of Field	2.18" to 14.17" @ 15.6 mil	
Resolution	4 mil	
Scanning Angle	Pitch \pm 60° Skew \pm 60°	
Scan Rate	230 scans per second	
Largest Readable Label Width	7.87"	
Ambient Light Rejection	10000Lux/Max (Fluorescent Light)	
FEATURES		
Supported Symbologies	Code 39/Full ASCII, Codabar, Industrial 2 of 5, Interleave 2 of 5, Matrix 2 of 5, Code 93, Code 128, Code 32, Standard Code 39, EAN 128, MSI, EAN 8&13, UPCA & E, Plessey, DataBar14, TELEPEN	
Programmable Features	Code ID, Prefix Code, Postfix Code, Length Code, Barcode Type, Buzzer Frequency, ISBN/ISSN/CLSI/UK Plessey Conversion, Keyboard Layout, Inter-Character Delay, Scanning Mode, Language Type, Time Out, Baud Rate, Data Bit, Transmission Mode, Character Replace	
BLUETOOTH® CLASS 1		
Radio Frequency	2.4GHz	
Range	328 feet line of site	
PHYSICAL	Scanner	Cradle
Weight	5.6 oz \pm 0.35 oz	8 oz \pm 0.35 oz
Housing	ABS	ABS
Dimensions	3.6"(L) x 2.9"(W) x 6.9"(H)	7.92"(L) x 4.37"(W) x 2.76"(H)
Color	Black	Black
ELECTRICAL		
Battery	Lithium-ion 1620mAh	
Operating Time	50,000 scans per charge	
POWER CONSUMPTION	<1200 mW (Operation)	
ENVIROMENTAL		
Temperature	32° - 122° F	
Humidity	20% - 85% non-condensing (operation)	
Shock Resistance	Withstands multiple drops from 6.5' onto a concrete surface	
WARRANTY	3 Year Limited	
CERTIFICATIONS	FCC Class B, CE, C-tick, RoHs	

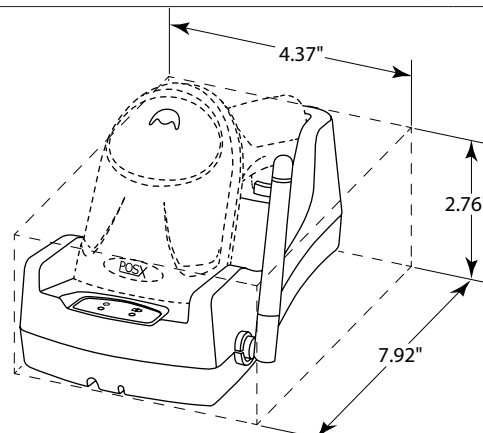

POS-X, Inc. 1975 Midway Lane Suite O Bellingham, WA 98226
 www.pos-x.com sales@pos-x.com tel 1.800.790.8657 fax 360.738.3495